

# SMART SOLUTIONS FOR THE LABELING INDUSTRY

## MOTORIZED CORE HOLDER XL (MCH XL)

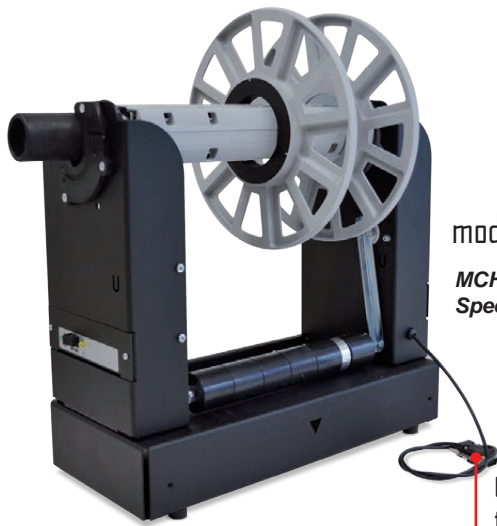

model **MCH51URXL**  
MCH XL Unwinder  
Speed 51rpm

Connector  
to the printer

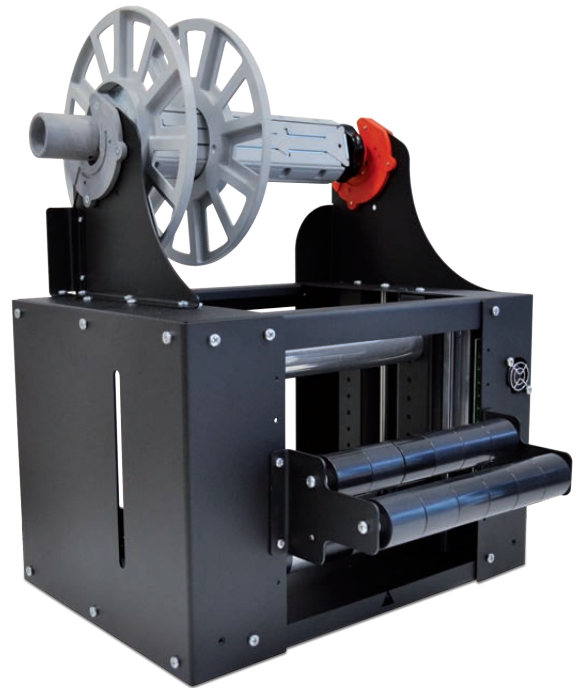

model **MCH100RUXL**  
MCH XL Rewinder  
Speed 100rpm

Our MCH XL Unwinders & Rewinders are the perfect companions to most digital inkjet label printers.

Thanks to its revolutionary design and solidly manufactured quality, the MCH XLs are perfect for high usage and heavy duty jobs.

The MCH XLs can handle labels up to 240mm (9.45") wide, and rewind or unwind rolls with OD up to 250mm (9.84"). Rolls are rewinded/unwinded onto/from a 3" core holder.

- High-volume roll-to-roll production
- Ideal for the Memjet-powered
- Sturdy steel construction
- Up-rated, industrial-quality motors

With the clutch system on MCH100RUXL it is possible to obtain different levels of roll tightness.

The below image will help you figure out the level you want the system to rewind your rolls.

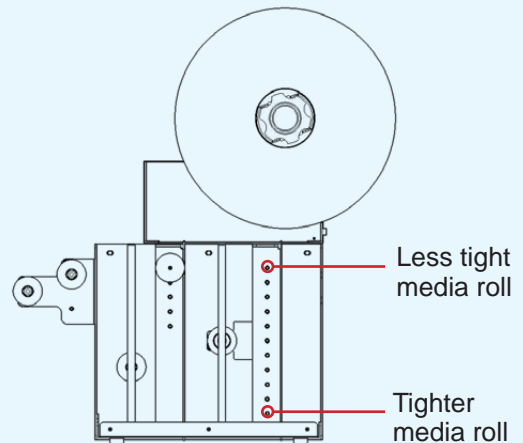

Unwinder printer plate



Rewinder printer plate

## PRINTER PLATE INCLUDED

The printer must be put onto the unwinder or rewinder's printer plate, in this way the correct unwinding/rewinding operations are guaranteed and also the units are fastened to the printer.